



## Planetary Mixers Planetary Mixer, 20 lt - Floor Model, with Hub, Three Phase

ITEM # \_\_\_\_\_

MODEL # \_\_\_\_\_

NAME # \_\_\_\_\_

SIS # \_\_\_\_\_

AIA # \_\_\_\_\_



**600152 (DXBM20A3B)**

20 lt planetary mixer, bowl detection device and SOLID BPA free safety screen, with mechanical speed variation. Floor model. Equipped with spiral hook, paddle, whisk and H type accessory hub

### Short Form Specification

Item No. \_\_\_\_\_

Floor model, suitable for all kneading, blending and whipping operations. Body in non-corrosive material with 20 litre 18/8 (AISI 302) stainless steel bowl. Powerful asynchronous motor (750 W) with mechanical speed variator (8 speed levels from 35 to 180 rpm). Water protected planetary system. Removable/transparent solid safety screen - made of a bisphenol-A free (BPA) copolyester. Water proof (IP55) and flat touch button control panel with 60 min. timer. Bowl detection device allows the mixer to switch on only when the bowl and the safety screen are properly installed and positioned together. Adjustable feet for stability. Equipped with accessory drive hub type H (accessories are not included). Supplied with 3 tools: spiral hook, paddle and whisk.

### Main Features

- Professional beater mixer that provides all the basic mixer functions: kneading of all sort of pastes, mixing of semi-liquid products, emulsions and various sauces.
- Delivered with:
  - Spiral Hook, Paddle, Wire Whisk and Mixing Bowl for 20 lt
  - Accessory drive hub (accessories are not included)
- Waterproof touch button control panel with timer setting and display.
- Mechanical speed variator.
- Maximum capacity (flour, with 60% of hydration) 6 kg, suitable for 50-150 meals per service.
- Raising and lowering of the bowl controlled by lever with an automatic locking of the bowl when in the raised position.
- Solid BPA-free safety screen, covering the stainless steel wire one, limits the flour and unsafe dust particles when used in bakery and pastry preparation.
- Removable chute to add ingredients while working included as standard.
- Bowl detection device allows the mixer to switch on only when the bowl and the solid safety screen are properly installed and positioned together.

### Construction

- Body in non-corrosive material.
- Sturdy construction with mechanically welded strong metal frame.
- 302 AISI Stainless steel bowl - 20 lt. capacity.
- Asynchronous motor with high start-up torque.
- 8 speeds, from 35 to 180 prm, to be lever operated while the machine is working, according to the tool and the mixture hardness.
- Planetary movement based on self lubricating gears, eliminating any risk of leaks.
- Power: 750 watts.
- Water protected planetary system (IP55 electrical controls, IP34 appliance overall).
- The solid safety screen and the stainless steel wire structure are both removable and dismantled for cleaning and are dishwasher safe.
- Adjustable feet for perfect stability.

### Included Accessories

- 1 of BOWL FOR 20LT MIXER PNC 650121
- 1 of WHISK FOR 20LT MIXER PNC 653109
- 1 of DOUGH HOOK FOR 20LT MIXER PNC 653114
- 1 of PADDLE FOR 20LT MIXER PNC 653116

### Optional Accessories

- BOWL FOR 20LT MIXER PNC 650121 □

APPROVAL: \_\_\_\_\_



## Planetary Mixers Planetary Mixer, 20 lt - Floor Model, with Hub, Three Phase

- 10L BOWL,HOOK,PADDLE,WHISK FOR 20L MIXER PNC 650122
- WHISK FOR 20LT MIXER PNC 653109
- DOUGH HOOK FOR 20LT MIXER PNC 653114
- PADDLE FOR 20LT MIXER PNC 653116
- PUREE STRAINER FOR H HUB WITH 3 GRIDS PNC 653187
- VEGETAB.CUTTER H HUB+ EJECTOR-DISCONNECT. PNC 653225
- REINFORCED WHISK FOR 20LT MIXER PNC 653254
- KIT WHEELS FOR (XB)20/30/40L PLAN.MIXERS PNC 653552
- EXT.SUPPORT(ALUM)-MEAT MINCER 70MM-H HUB PNC 653720
- ALUM.MEATMINCER KIT 70MM-H HUB-ENTERPRIS PNC 653721
- S/S MEATMINCER KIT 70MM-H HUB-ENTERPRISE PNC 653722
- S/S MEATMINCER KIT 70MM-H HUB-½ UNGER PNC 653723



Front

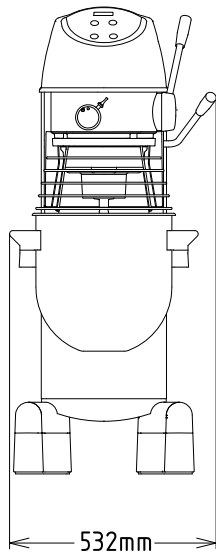

Electric

<b>Supply voltage:</b>	200-240/380-415 V/3 ph/50 Hz
<b>Electrical power max.:</b>	0.75 kW
<b>Total Watts:</b>	0.75 kW

Capacity:

<b>Performance (up to):</b>	6 kg/Cycle
<b>Capacity:</b>	20 litres

Key Information:

<b>External dimensions, Width:</b>	521 mm
<b>External dimensions, Depth:</b>	685 mm
<b>External dimensions, Height:</b>	1230 mm
<b>Shipping weight:</b>	114 kg
<b>Net weight (kg):</b>	95
<b>Cold water paste:</b>	6 kg with Spiral hook
<b>Egg whites:</b>	32 with Whisk

Side

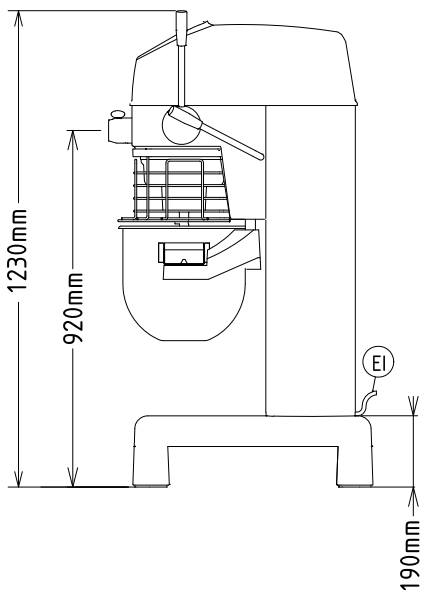

EI = Electrical inlet (power)

Top

